

# PTTC Tube Cutter (Push Type Tube Cutter)

For Tube OD Range 3/8" and 5/8"-2-1/2"



Tube & Pipe Cleaners ◦ Tube Testers ◦ Tube Plugs ◦ Tube Removal ◦ Tube Installation



## Operating and Maintenance Instructions



# Table Of Contents

Introduction .....	4
Safety Instructions.....	5
Operation Instructions.....	6
Tool Tips .....	8
Tool Adjustments and Replacements.....	9
Parts List .....	12

# **INTRODUCTION**

Thank you for purchasing this Elliott product. More than 100 years of experience have been employed in the design and manufacture of this control, representing the highest standard of quality, value and durability. Elliott tools have proven themselves in thousands of hours of trouble free field operation.

If this is your first Elliott purchase, welcome to our company; our products are our ambassadors. If this is a repeat purchase, you can rest assured that the same value you have received in the past will continue with all of your purchases, now and in the future.

The PTTC Tube Cutter has been designed for the following types of equipment:

**Boilers**

**Chillers**

**Heat Exchangers**

**Fin Fan Coolers**

**Sugar Mill Vacuum Pans**

**Surface Condensers**

If you have any questions regarding this product, manual or operating instructions, please call Elliott at +1 800 332 0447 toll free (USA only) or +1 937 253 6133, or fax us at +1 937 253 9189 for immediate service.

# **SAFETY INSTRUCTIONS**

1. Remove the tool from the drive motor prior to changing cutter blades or cutter pilots.
2. Always wear safety glasses when using this equipment.
3. The Elliott PTTC Tube Cutter is a rotating cutter. Avoid wearing loose clothing and jewelry. Wear protective hair covering to prevent long hair from getting caught in the tool.
4. Do not use this tool if it appears damaged.
5. Never use the Tube Cutter, or any other power tool when under the influence of medication, drugs or alcohol that decrease concentration and impair operator control.

# OPERATING INSTRUCTIONS

1. Select the proper Elliott PTTC Tube Cutter for the tube size.  
(Each tube OD requires a different size Tube Cutter.)
2. Your Elliott PTTC Tube Cutter is supplied with a complete set of Cutter Pilots for the most common gauge sizes that the tool can accommodate. Install the appropriate pilot for the tube wall gauge being cut. Use CHART 1 for pilot selection. See “Tool Adjustment and Component Replacement” for installation instructions.
3. Set the Thrust Assembly to the desired depth of cut inside the tube sheet.  
See “Tool Adjustment and Component Replacement” on page 9 for instructions.
4. Adjust the cutter blade(s) to either score or cut through the tube wall. Scoring will allow chips to be cleared from the tubes prior to pulling. The pulling operation will stretch the tube and snap it at the cut. If a through cut is specified, adjust the tool so that it cuts just beyond the tube OD. See “Tool Adjustment and Component Replacement” on page 9 for instruction.
5. The Elliott PTTC Tube Cutter can be driven with either an electric or pneumatic motor. Refer to Chart 2 for recommended starting RPM speeds for the material type and tube size being cut. NOTE: Operating the tube cutter at too high a RPM can result in “burning” the cutter blade(s), reducing the cutter blade(s) life.
6. Once all adjustments are made, insert the cutter into the tube to be cut. Activate the motor, which will rotate the cutter. Apply steady forward pressure to the cutter, which will advance the cutter blade(s) out to the tube wall. NOTE: Do not jam the cutter blade(s) into the tube wall. This may result in a broken cutter blade(s) or damage to the tool. When the cut is complete stop the drive motor. Release the forward pressure, which will retract the cutter blade(s) and move the tool to the next tube. NOTE: Use a cutting fluid to promote cutter blade life.

# OPERATING INSTRUCTIONS (CONT.)

**CHART 1 - Standard Pilot Numbers:\***

	ga	9ga	10ga	11ga	12ga	13ga	14ga	15ga	16ga	17ga	18ga	19ga	20ga	21ga	22ga
PTTC625P(xx)									16	16	18	18	20	20	20
PTTC750P(xx)							14	14	16	16	18	18	20	20	20
PTTC875P(xx)					12	12	14	14	16	16	18	18	20	20	20
PTTC1000P(xx)					12	12	14	14	16	16	18	18	20	20	20
PTTC1250P(xx)					12	12	14	14	16	16	18	18			
PTTC1500P(xx)			10	10	12	12	14	14	16	16					
PTTC1750P(xx)					12	12	14	14	16	16					
PTTC2000P(xx)			10	11	12	13	14								
PTTC2500P(xx)			10	11	12	13	14								

\* Pilot not required for PTTC375-22

**CHART 2 - Recommended Starting RPM for Tube Cutter:**

TUBE O.D.	TUBE MATERIAL											
	Inconel 10 SFM	Hastelloy 20 SFM	300 Series Stainless 30 SFM	Monel 40 SFM	400 Series Stainless 50 SFM	Titanium 60 SFM	Carbon Steels 80 SFM	Copper 90 SFM	Copper-Nickel 100 SFM	Red Brass 200 SFM	Admiralty Brass 225 SFM	Aluminum 250 SFM
1/4"	153	306	458	611	764	917	1222	1376	1528	3056	3438	3820
5/16"	122	244	367	489	611	733	978	1100	1222	2445	2750	3056
3/8"	102	204	306	408	509	611	815	916	1018	2037	2292	2546
7/16"	87	175	262	349	437	524	699	786	874	1746	1964	2183
1/2"	76	153	229	306	382	459	611	688	764	1528	1719	1910
9/16"	68	137	204	272	340	407	543	611	679	1358	1528	1698
5/8"	61	122	184	245	306	367	489	552	612	1222	1375	1528
11/16"	55	112	167	222	278	333	444	500	555	1111	1250	1389
3/4"	51	102	153	203	254	306	408	458	508	1019	1146	1273
13/16"	47	95	142	190	237	284	379	427	474	940	1058	1175
7/8"	44	87	131	175	219	262	349	392	438	873	982	1091
1"	38	76	115	153	191	229	306	344	382	764	859	955
1-1/8"	34	68	102	136	170	204	272	306	340	679	764	849
1-1/4"	31	61	92	123	153	183	245	274	306	611	688	764
1-3/8"	28	56	83	111	139	167	222	250	278	556	625	694
1-1/2"	25	51	76	102	127	153	204	230	254	509	573	637
1-3/4"	22	44	66	88	109	131	175	196	218	437	491	546
2"	19	38	57	76	96	115	153	172	191	382	430	477

## **TOOL TIPS**

1. The cutter blades supplied with your Elliott tube cutter are specially coated to provide up to three times longer life than a standard high speed steel blade. Use of cutting fluid will contribute to even greater blade life.
2. Different tube materials and tube sizes require different cutting speeds. Refer to Chart 2 for cutting speed recommendations. Excessive cutting speed will reduce the life of, or may damage the cutter blade.
3. Excessive pressure when cutting (forcing rapid feed-rate) will reduce the life of the cutter blade. Moderate and steady pressure is recommended.
4. Cutter blades with a dull or chipped cutting edge should be replaced with a new blade.
5. Cutting tools should never be run in reverse.
6. Tube cutters should never be operated at an angle to the tube centerline. The Elliott PTTC Tube Cutter is equipped with an adjustable centering thrust assembly to insure that the tool is setting parallel to the centerline of the tube, avoiding tool breakage.

## **TOOL CARE**

1. Before each use inspect your Elliott PTTC Tube Cutter for damaged or worn cutter blade(s).
2. Always make sure the cutter blade(s) is sharp and not chipped.
3. Use a cutting fluid to reduce cycle time and increase blade life.
4. Operate your Elliott PTTC Tube Cutter at the proper speed for the material type and size being cut. This will contribute to longer cutter blade life.
5. After each use clean the tool and apply a light oil to prevent rust and tarnish during storage.



# **TOOL ADJUSTMENTS AND REPLACEMENTS**

## **Adjusting the Depth of Cut:**

The depth of the cut can be adjusted up to 5" with the Thrust Assembly, or up to 6" with the Thrust Assembly removed.

1. Loosen the two (2) set screws in the Thrust Assembly. (Chart 3 - Detail 4)
2. Slide the Thrust Assembly to the desired position and tighten the set screws.

## **Adjusting the Cutter Blade Projection:**

The Elliott PTTC Tube Cutter can be adjusted to cut completely through the tube wall or to score the inside of the tube wall.

1. Secure the Drive Shank (Chart 3 – Detail 6) with a wrench.
2. Using a wrench, position the Adjustment Nut (Chart 3 – Detail 5) to the desired depth. Thread the Adjustment Nut toward the Cutter Body for a shallow cut and away from the Cutter Body for a deeper setting.
3. Test cut a sample tube. For scoring the tube, adjust the tool to produce a perceivable bulge on the tube OD. If the intent is to cut through the tube, adjust the tool to just clear the tube OD. NOTE: It may take several test cuts to achieve the desired cut.

## **Replacing the Tube Cutter Pilot:**

1. Using a drift, drive the cutter pin out of the tube cutter. (Chart 3, Detail 3)
2. Remove the cutter blade(s). (Chart 3, Detail 2)
3. Slide the pilot off and replace with the new pilot. (Chart 3, Detail 1)
4. Replace the cutter blade(s) and cutter pin. See "Replacing the Cutter Blade" steps 3, 4 and 5.

## **Replacing the Cutter Blade:**

1. Using a drift, drive the spring pin (Chart 3, Detail 3) out of the tube cutter.
2. Remove the worn cutter blade(s). (Chart 3, Detail 2)
3. Insert the new cutter blade(s) with the slot fitting the blade properly in the plunger inside the tube cutter.
4. Using a probe, line up the holes in the cutter body with the hole in the cutter blade(s).
5. Carefully drive the spring pin into the cutter body and through the cutter blade.

# ELLIOTT TUBE CUTTER

Tube OD	Cutter Kit # (Includes Pilot Set)	Drive Shank Size	Non-Ferrous / Steel Blade with Pin #	Stainless Steel Blade with Pin #	# of Blades	*Cutter Pin #	Number of Pilots in a Set	Tube Gauge Sizes for Pilot
3/8" (9.53mm)	PTTC375-22**	1/2"Hex	PTTC25210	-	1	PTTC375-22D10	-.**	22-24
5/8" (15.9mm)	PTTC625K		PTTC25186	PTTC25186S1	1	PTTC625CP	3	16-17, 18-19, 20-22
3/4" (19.1mm)	PTTC750K		PTTC25186-1	PTTC25186S2	1	PTTC750CP	4	14-15, 16-17, 18-19, 20-22
7/8" (22.2mm)	PTTC875K		PTTC25194	PTTC25194S1	1	PTTC875CP	5	12-13, 14-15, 16-17, 18-19, 20-22
1" (25.4mm)	PTTC1000K		PTTC25199	PTTC25199S1	2	PTTC1000CP	5	12-13, 14-15, 16-17, 18-19, 20-22
1-1/4" (31.8mm)	PTTC1250K	3/4" Sq	PTTC25206	PTTC25206S1	2	PTTC1250CP	4	12-13, 14-15, 16-17, 18-19
1-1/2" (38.1mm)	PTTC1500K		PTTC25206-1	PTTC25206S2	2	PTTC1500CP	4	10-11, 12-13, 14-15, 16-17
2" (50.8mm)	PTTC2000K		PTTC25221	PTTC25221S1	2	PTTC2000CP	5	10, 11, 12, 13, 14
2-1/2" (63.5mm)	PTTC2500K		PTTC25223	PTTC25223S1	2	PTTC2500CP	5	10, 11, 12, 13, 14

\*Note: Included with cutter blade but can be purchased separately.

\*\*The 3/8" (9.5mm) PTTC Tube Cutter Assembly does not require pilots. To be used only with P5154 drive motor.

# ELLIOTT TUBE CUTTER

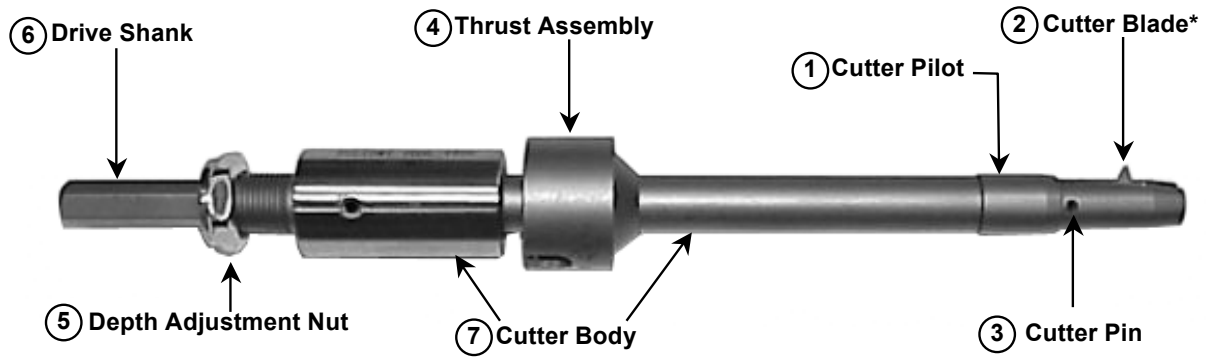

Pilot not required for PTTC375-22

# PARTS LIST

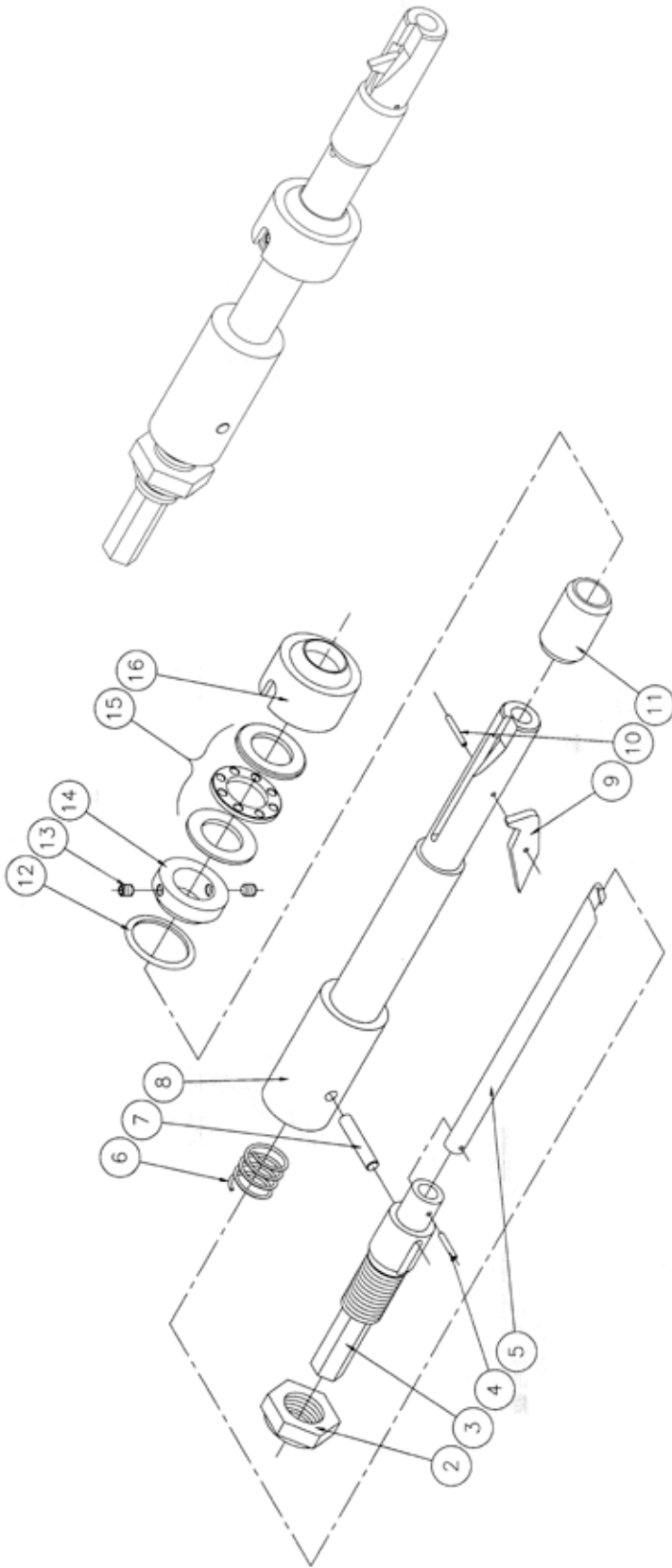

**TUBE CUTTER PILOT PART NUMBERS (ITEM #11)**

Wall Gauge (BWG)	Tube O.D. (inches)										
	5/8"	3/4"	7/8"	1"	1-1/4"	1-1/2"	1-3/4"	2"	2-1/2"		
10						PTTC1500P10		PTTC2000P10	PTTC2500P10		
11								PTTC2000P11	PTTC2500P11		
12			PTTC875P12	PTTC1000P12	PTTC1250P12	PTTC1500P12	PTTC1750P12	PTTC2000P12	PTTC2500P12		
13								PTTC2000P13	PTTC2500P13		
14								PTTC2000P14	PTTC2500P14		
15			PTTC750P14	PTTC1000P14	PTTC1250P14	PTTC1500P14	PTTC1750P14				
16	PTTC625P16	PTTC750P16	PTTC875P16	PTTC1000P16	PTTC1250P16	PTTC1500P16	PTTC1750P16				
17											
18	PTTC625P18	PTTC750P18	PTTC875P18	PTTC1000P18	PTTC1250P18						
19											
20	PTTC625P20	PTTC750P20	PTTC875P20								
21											
22											

Pilots shown are standard and are supplied with complete Tube Cutters for each tube O.D. size. Additional sizes may be ordered special. Consult the factory for availability.

# PARTS LIST

Item #	Part Name	3/8"	5/8"	3/4"	7/8"	1"	1-1/4"	1-1/2"	1-3/4"	2"	2-1/2"
2	Stop Nut	546R	546R	546R	546S	546S	PTTC1250D2	PTTC1250D2	PTTC1250D2	PTTC1250D2	PTTC1250D2
3	Drive Shank	PTTC500-14D3	PTTC625D3	PTTC625D3	PTTC875D3	PTTC1000D3	PTTC1500D3	PTTC1500D3	PTTC1500D3	PTTC2000D3	PTTC2000D3
	Drive Size	1/2 Hex	1/2 Hex	1/2 Hex	1/2 Hex	1/2 Hex	3/4 Square	3/4 Square	3/4 Square	3/4 Square	3/4 Square
4	Spring Pin	P8779-14	P8779-12	P8779-12	P8780-16	P8780-16	P8771-22	P8771-22	P8771-22	P8771-22	P8771-22
5	Plunger	PTTC500D5	PTTC625D5	PTTC625D5	PTTC875D5	PTTC1000D5	PTTC1500D5	PTTC1500D5	PTTC1500D5	PTTC2000D5	PTTC2000D5
	Plunger Qty	1	1	1	1	2	2	2	2	2	2
6	Spring	37-91935	PTTC625D6	PTTC625D6	37-72192	37-72192	37-S-3061	37-S-3061	37-S-3061	37-S-3061	37-S-3061
7	Spring Pin	P8780-24	P8780-26	P8780-26	P8771-34	P8771-30	P8387-24	P8387-24	P8387-24	P8387-24	P8387-24
8	Body	PTTC375-22D8D8	PTTC625D8	PTTC750D8	PTTC875D8	PTTC1000D8	PTTC1250D8	PTTC1500D8	PTTC1750D8	PTTC2000D8	PTTC2500D8
9	Cutter*	PTTC25210	PTTC25186	PTTC25186	PTTC25194	PTTC25199	PTTC25206	PTTC25206	PTTC25206	PTTC25221	PTTC25223
	Cutter Qty	1	1	1	1	2	2	2	2	2	2
10	Cutter Pin	PTTC375-22D10	PTTC625CP	PTTC750CP	PTTC875CP	PTTC1000CP	PTTC1250CP	PTTC1500CP	P8771-36	PTTC2000CP	PTTC2500CP
11	Pilot	NA	See Table	See Table	See Table	See Table	See Table	See Table	See Table	See Table	See Table
12	Ret. Spring	NA	P8368-112	P8368-112	P8368-137	P8368-137	P8368-165	P8374-185	P8374-212	P8374-237	P8374-306
13	Set Screw	128L	128YY	128YY	128YY	128YY	128YY	128YY	128YY	128YY	128YY
14	Thrust Nut	NA	PTTC625D16	PTTC750D16	PTTC875D16	PTTC1000D16	PTTC1250D16	PTTC1500D16	PTTC1750D16	PTTC2000D16	PTTC2500D16
15	Thrust Bearing	NA	PC80-51102	PC80-51102	PC80-51104	PC80-51104	PC80-51105	PC80-51106	PC80-51107	PC80-51108	PC80-51111
16	Thrust Collar	PTTC375-22D18	PTTC625D18	PTTC750D18	PTTC875D18	PTTC1000D18	PTTC1250D18	PTTC1500D18	PTTC1750D18	PTTC2000D18	PTTC2500D18

\*Includes Cutter Pin (Item 10)





## Contact Us

Elliott Tool offers a complete line of precision tube tools to meet your needs. Contact us or your local support.

Elliott Tool Technologies, Ltd.  
17 60 Tuttle Avenue  
Dayton, Ohio 45403-3428  
Phone: +1 937 253 6133 • +1 800 332 0447  
Fax: +1 937 253 9189  
[www.elliott-tool.com](http://www.elliott-tool.com)

Printed in the USA  
©05/2013 Elliott Tool Technologies, Ltd.  
TM-35  
PL-7

### Locally Supported By:

[www.elliott-tool.com/support](http://www.elliott-tool.com/support)